

OLYMPUS®

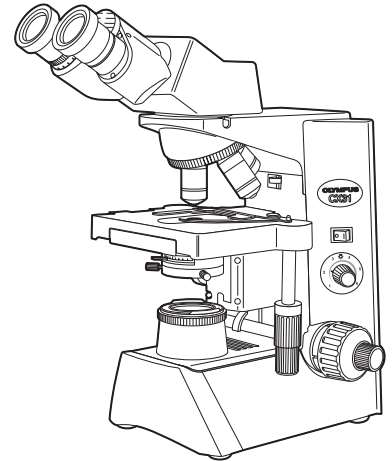

INSTRUCTIONS

CX31

BIOLOGICAL MICROSCOPE

This instruction manual is for the Olympus Biological Microscope Model CX31. To ensure the safety, obtain optimum performance and to familiarize yourself fully with the use of this microscope, we recommend that you study this manual thoroughly before operating the microscope. Retain this instruction manual in an easily accessible place near the work desk for future reference.



A X 6 6 5 4

CONTENTS

	Page
IMPORTANT – Be sure to read this section for safe use of the equipment. –	1-3
1 NOMENCLATURE	4
2 SUMMARY OF BRIGHTFIELD OBSERVATION PROCEDURE	5
3 ASSEMBLY – See this section for the replacement of the light bulb. –	6-7
4 USING THE CONTROLS	8-14
4-1 Base.....	8
1 Turning On the Bulb 2 Field Iris Diaphragm	
4-2 Focusing Block.....	9
1 Adjusting the Coarse Adjustment Knob Tension 2 Simplified Pre-focusing Dial	
4-3 Stage.....	10-11
1 Placing the Specimen 2 Moving the Specimen	
4-4 Observation Tube.....	11-12
1 Adjusting the Interpupillar Distance 2 Adjusting the Tilt 3 Adjusting the Diopter	
4 Using the Eye Shades 5 Using the Eyepiece Micrometer Disk	
4-5 Condenser.....	13
1 Centering the Field Iris Diaphragm 2 Aperture Iris Diaphragm	
4-6 Immersion Objectives.....	14
1 Using the Immersion Objectives	
5 TROUBLESHOOTING GUIDE	15-16
6 SPECIFICATIONS	17
7 OPTICAL CHARACTERISTICS	18
■ PROPER SELECTION OF THE POWER SUPPLY CORD.....	19-20

IMPORTANT

! SAFETY PRECAUTIONS

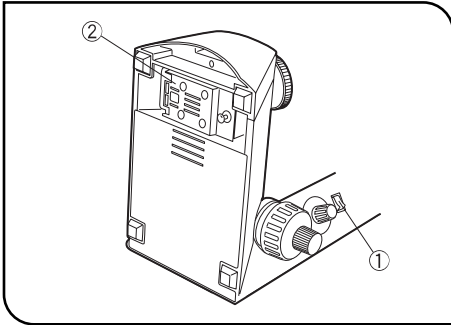





Fig.1

1. After the equipment has been used in an observation of a specimen that is accompanied with a potential of infection, clean the parts coming in contact with the specimen to prevent infection.
 - Moving this product is accompanied with the risk of dropping the specimen. Be sure to remove the specimen before moving this product.
 - In case the specimen is damaged by erroneous operation, promptly take the infection prevention measures.
2. To avoid potential shock hazard and fire, always set the main switch ① to "O" (OFF) and disconnect the power cord from the AC receptacle at the rear of the microscope and from the wall outlet before replacing the bulb. Allow the lamp housing cover ② and the bulb to cool before touching them.
3. Install the microscope on a sturdy, level table.

The air vents on the underside of the base should never be blocked by placing the microscope on a flexible surface such as a carpet, as this could result in overheating and cause a fire.
4. Always use the power cord provided by Olympus. If no power cord is provided, please select the proper power cord by referring to the section "PROPER SELECTION OF THE POWER SUPPLY CORD" at the end of this instruction manual. If the proper power cord is not used, Olympus can no longer warrant the electrical safety and performance of the equipment.
5. When installing the microscope, route the power cord away from the microscope base. Should the power cord come in contact with the hot microscope base, the power cord could melt and cause electric shock.
6. Connect the power cord correctly and ensure that the grounding terminal of the power supply and that of the wall outlet are properly connected. If the equipment is not grounded, Olympus can no longer warrant the electrical safety and performance of the equipment.
7. Never set the main switch ① to "I" (ON) while any metallic object is inserted into the air vents of the microscope frame as this will result in electrical shock, personal injury and equipment damage.
8. When the microscope is not in use or when it is malfunctioning, disconnect the power cord plug from the AC receptacle or from the wall outlet.

Safety Symbols

The following symbols are found on the microscope. Study the meaning of the symbols and always use the equipment in the safest possible manner.

Symbol	Explanation
	Indicates that the surface becomes hot, and should not be touched with bare hands.
	Before use, carefully read the instruction manual. Improper handling could result in personal injury to the user and/or damage to the equipment.
	Indicates that the main switch is ON.
	Indicates that the main switch is OFF.

Warning Label

A warning label is affixed at parts where special precaution is required when handling and using the microscope. Always heed the warnings.

Warning label position:	Base underside (Caution for bulb replacement)	
-------------------------	---	---

If the warning label becomes soiled, peeled off, etc., contact Olympus to have it replaced.

1 Getting Ready

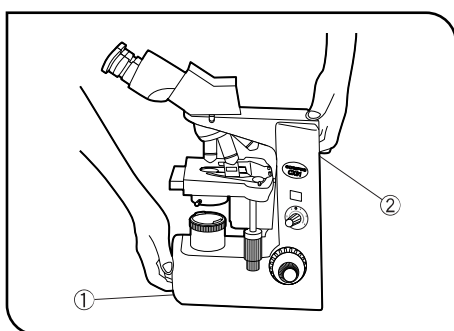

Fig. 2

1. A microscope is a precision instrument. Handle it with care and avoid subjecting it to sudden or severe impact.
 2. Do not use the microscope where it is subjected to direct sunlight, high temperature and humidity, dust or vibrations. (For the operating environment conditions, refer to and adhere to the conditions specified in Chapter 6, "SPECIFICATIONS" on page 17)
 3. The tension of the coarse focus adjustment knob should only be adjusted by means of the tension adjustment ring.
 4. Heat from the microscope is led away by natural convection. Consequently, leave an enough space (10 cm or more) on the rear of the microscope and ensure that the room is well ventilated.
 5. When moving the microscope, carefully carry it with one hand under the base ① and the other hand holding at the recessed handle on the rear of the arm ② as shown in the illustration on the left.
- ★Damage to the microscope will occur if you hold it by the stage, X-axis/Y-axis knob, binocular section of the observation tube, etc. Also be sure to remove the specimen to prevent it from falling off.
- ★Sliding the microscope on the surface of the table may damage or tear off the rubber feet and/or scratch the table top surface.

1

Maintenance and Storage

1. Clean all glass components by wiping gently with gauze. To remove fingerprints or oil smudges, wipe with gauze slightly moistened with a mixture of ether (70%) and alcohol (30%).
▲ Since solvents such as ether and alcohol are highly flammable, they must be handled carefully. Be sure to keep these chemicals away from open flames or potential sources of electrical sparks -- for example, electrical equipment that is being switched on or off. Also remember to always use these chemicals only in a well-ventilated room.
2. Do not attempt to use organic solvents to clean the non-optical components of the microscope. To clean them, use a lint-free, soft cloth lightly moistened with a diluted neutral detergent.
3. Do not disassemble any part of the microscope as malfunction or damage may occur.
4. When not using the microscope, ensure that the frame is cooled down and store it in a locker or cover it with a dust cover.
5. When disposing of the microscope, check the regulations and rules of your local government and be sure to observe them.

3

Caution

If the microscope is used in a manner not specified by this manual, the safety of the user may be imperiled. In addition, the equipment may also be damaged. Always use the equipment as outlined in this instruction manual.

The following symbols are used to set off text in this instruction manual.

- ▲** : Indicates that failure to follow the instructions in the warning could result in bodily harm to the user and/or damage to equipment (including objects in the vicinity of the equipment).
- ★** : Indicates that failure to follow the instructions could result in damage to equipment.
- ◎** : Indicates commentary (for ease of operation and maintenance).

This device complies with the requirements of directive 98/79/EC concerning in vitro diagnostic medical devices. CE marking means the conformity to the directive.

NOTE : This equipment has been tested and found to comply with the limits for a Class A digital device, pursuant to Part 15 of the FCC Rules. These limits are designed to provide reasonable protection against harmful interference when the equipment is operated in a commercial environment. This equipment generates, uses, and can radiate radio frequency energy and, if not installed and used in accordance with the instruction manual, may cause harmful interference to radio communications. Operation of this equipment in a residential area is likely to cause harmful interference in which case the user will be required to correct the interference at his own expense.

FCC WARNING : Changes or modifications not expressly approved by the party responsible for compliance could void the user's authority to operate the equipment.

1 NOMENCLATURE

- ⊙The revolving nosepiece is fastened with a band to prevent it from turning during transportation. Remove the band when unpacking the microscope. Be sure to store the band for re-transportation of the microscope.
- * The stage is shipped with **the two transport pins locked**. When using the microscope for the first time, remove the transport lock pins before use.
- ⊙If you have not yet attached the lamp bulb and power cord to the microscope, read Chapter 3, "ASSEMBLY" on pages 6 to 7.

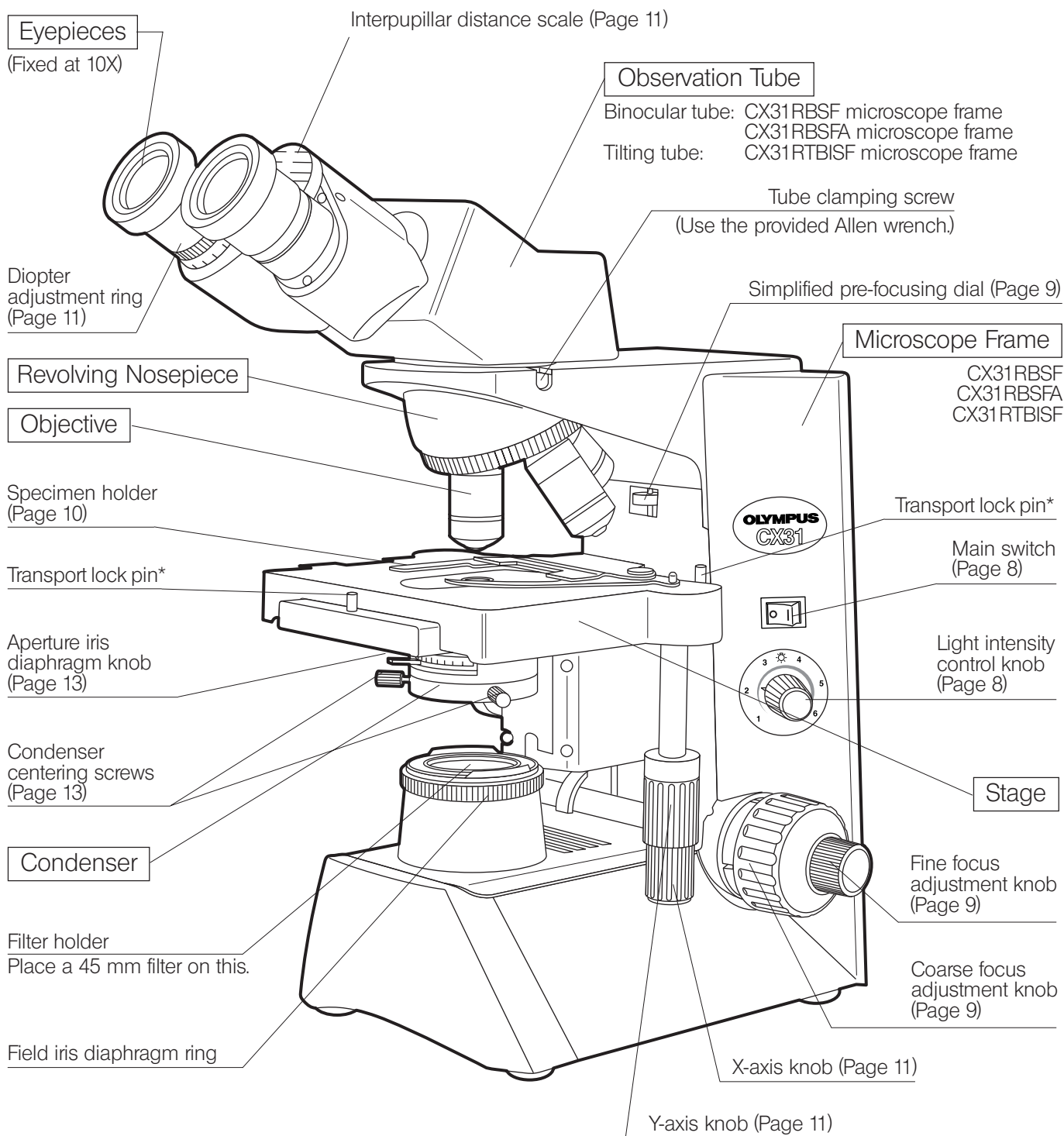

2

SUMMARY OF BRIGHTFIELD OBSERVATION PROCEDURE

1

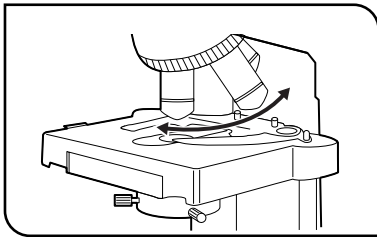

- Turn the revolving nosepiece to engage the 10X objective.
- ★Make sure that the revolving nosepiece stops with an audible click.

2

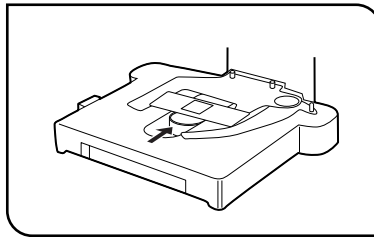

- Place a specimen on the stage. (Page 10)

3

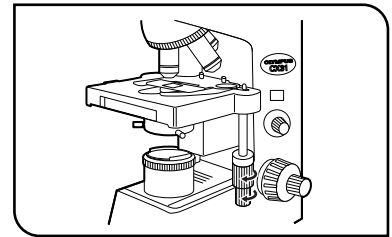

- Turn the X-axis knob and Y-axis knob to move the specimen into the light path. (Page 11)

4

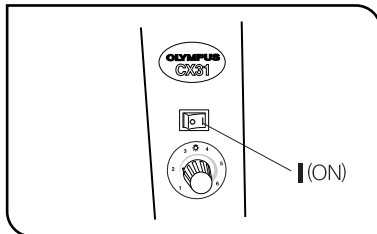

- Set the main switch to "I" (ON) and adjust the brightness with the light intensity knob. (Page 8)

5

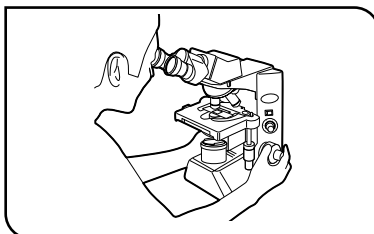

- Turn the coarse and fine adjustment knobs to bring the specimen into focus.

6

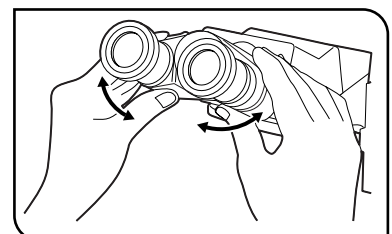

- Adjust the interpupillary distance. (Page 11)
- When the tilting observation tube is used, adjust the angle of tilt. (Page 11)

7

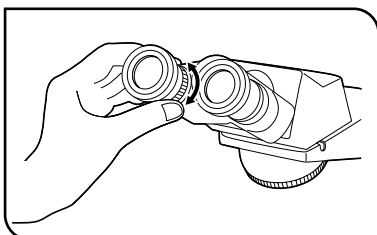

- Adjust the diopter. (Page 11)

8

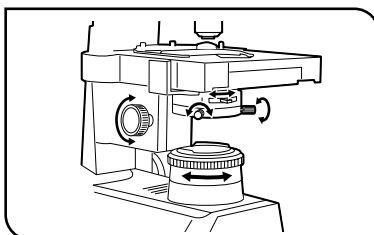

- Center the field iris diaphragm. (Page 13)

9

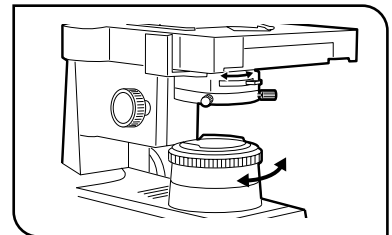

- Adjust the aperture iris diaphragm and field iris diaphragm. (Page 8)

10 Engage the objective to be used for observation in the light path, then readjust the focus.

11 Place the required filter on the filter holder.

12 Re-adjust the aperture iris diaphragm, field iris diaphragm and brightness and start observation.

3 ASSEMBLY

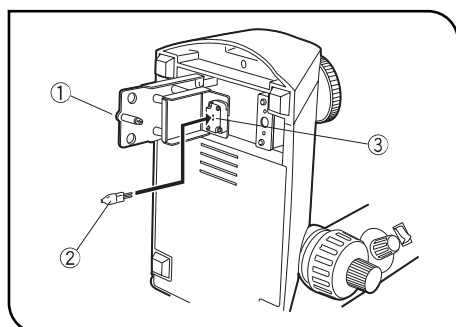

Fig. 3

1 Mounting the Bulb (Replacement of Bulb) (Fig. 3)

1. Turn the microscope frame on its side and pull the lamp housing knob ① on the underside of the base to open the lamp housing cover.
2. Holding the halogen bulb ② contained in the polyethylene bag to avoid leaving fingerprints on the bulb, fully insert the contact pins into the bulb socket ③. When properly seated, pull off the polyethylene bag.

◀Applicable bulb▶

6 V, 30 W halogen bulb: 6V30WHAL (Philips 5761)

▲ Always use the designated bulb. Use of improper bulb may result in fire.

▲ Do not touch the bulb with bare hands. If fingerprints are accidentally left on the bulb, wipe the bulb with a soft, lint-free cloth moistened with alcohol. Using a contaminated bulb will shorten the service life of the bulb.

3. With the lamp housing knob still pulled out, close the lamp housing cover. Then push in the lamp housing knob to lock the cover.

★ The lamp housing cover cannot be closed if the knob is pushed in before you attempt to close the cover.

Caution for Bulb Replacement During Use or Right After Use

▲ Whenever you replace the bulb during use or right after use, first move the main switch to “ O ” (OFF), disconnect the power cord from the wall outlet, and allow the bulb and parts around the bulb to cool before touching.

★ If the bulb burns out during an observation and needs to be replaced, remove the specimen, filter and other objects likely to fall off, before tilting the microscope frame to replace the bulb.

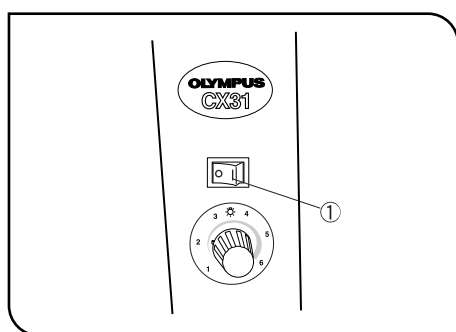

Fig. 4

2 Connecting the Power Cord (Figs. 4 - 6)

▲ Cables and cords are vulnerable when bent or twisted. Never subject them to excessive force.

▲ Make sure that the main switch ① is set to “ O ” (OFF) before connecting the power cord. (Fig. 4)

▲ Always use the power cord provided by Olympus. IF no power cord is provided with the microscope, please select the proper power cord by referring to section “ROPER SELECTION OF THE POWER SUPPLY CORD” at the end of this instruction manual.

1. Connect the power cord plug ② to the AC receptacle ④. (Fig. 5)

▲ Connect the power cord to a grounded, 3-conductor power outlet and ensure that the ground terminal of the power supply and that of the wall outlet are properly connected. If the equipment is not grounded, Olympus can no longer warrant the electrical safety performance of the equipment.

2. Plug the power cord plug ④ into the wall outlet ⑤. (Fig. 6)

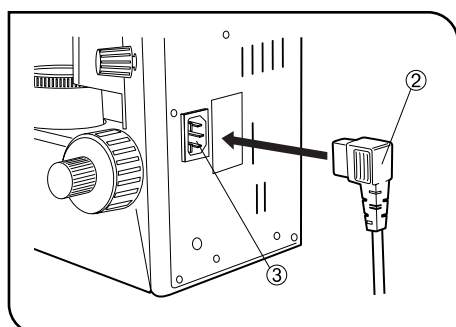

Fig. 5

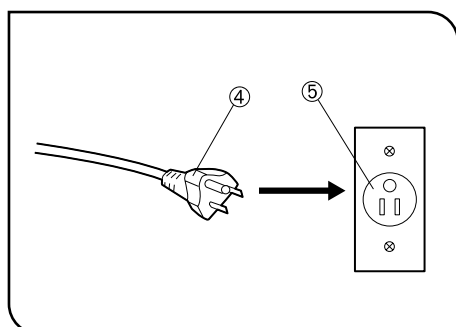

Fig. 6

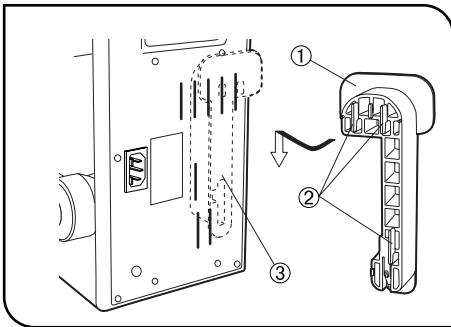

Fig. 7

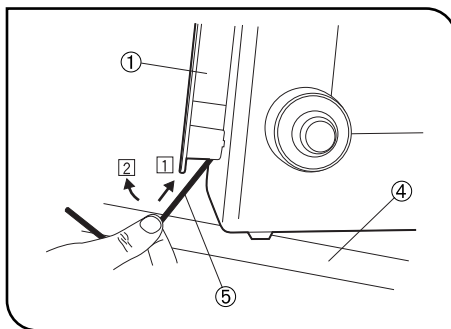

Fig. 8

3 Attaching the Optional Cord Hanger (CH3-CH) (Figs. 7 & 8)

◎By attaching the optional CH3-CH cord hanger on the rear of the microscope frame, the power cord can be accommodated by winding around the hanger.

Insert the hook ② of the cord hanger ① into the air vent groove on the rear of the microscope by aligning the attaching position ③, and clamp by sliding the cord hanger downward while pushing it against the microscope with a strong force.

★Do not hold the microscope frame by the cord hanger when carrying the microscope. Otherwise, the cord hanger may be detached during transport, resulting in falling of the microscope and personal injury.

Removal

▲To prevent electric shock, disconnect the power cord first. Also make sure you use the provided Allen wrench, not a thin Allen wrench.

Move the microscope frame to the edge of the table ④, apply an Allen wrench ⑤ onto the lower part of the cord hanger ①, and move the entire hanger upward by pushing the Allen wrench toward the directions ① and ② to remove. (Fig. 8)

4 USING THE CONTROLS

4-1 Base

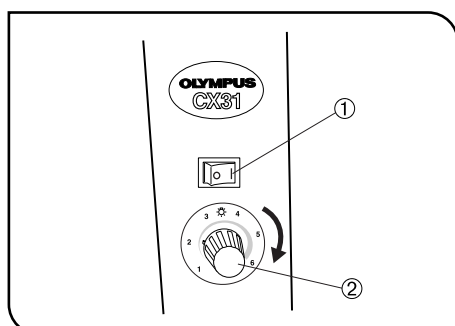

Fig. 9

1 Turning On the Bulb

(Fig. 9)

1. Set the main switch ① to " I " (ON).
2. Turn the light intensity knob ② clockwise in the direction of the arrow to make the illumination brighter or counterclockwise to make it darker. The numbers around the knob indicates the reference voltage values.

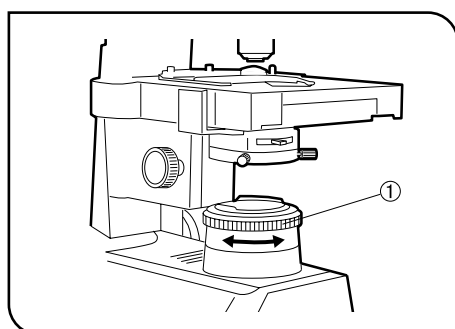

Fig. 10

2 Field Iris Diaphragm

(Fig. 10)

Using the field iris diaphragm ring ①, adjust the diameter of the field iris for objective power to the extent that it just circumscribes the field of view. When the field iris diaphragm is stopped down to circumscribe the field of view, it will exclude extraneous light and improve image contrast within the field of view.

- ★When using the 100X objective, the field iris diaphragm image will not be visible within the field of view. Accordingly, stop down the diaphragm to its smallest diameter.

4-2 Focusing Block

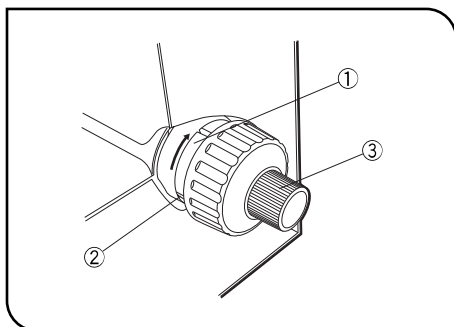

Fig. 11

1 Adjusting the Coarse Adjustment Knob Tension (Fig. 11)

1. The coarse adjustment knob tension is preadjusted for easy use. However, if desired, one can change the tension using the tension adjustment ring ①. Applying a large flat-bladed screwdriver to any of the grooves ② on the circumference of the ring, turning the ring clockwise (in the direction of the arrow) increases tension, and vice versa.
2. The tension is too low if the stage drops by itself or focus is quickly lost after adjustment with the fine adjustment knob ③. In this case, turn the ring in the direction of the arrow to increase tension.

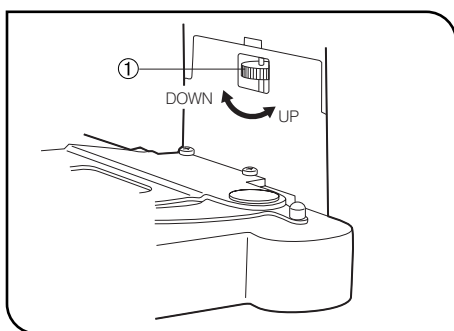

Fig. 12

2 Simplified Pre-focusing Dial (Fig. 12)

- Ⓞ This mechanism ensures that the objective does not come in contact with the specimen and damage it.
1. After focusing on the specimen, turn the simplified pre-focusing dial ① on the focusing block so that the mechanism contacts the stage holder.
 2. To allow a certain margin for the focused position, return the simplified pre-focusing dial by about a half turn from the position where the mechanism contacts the stage holder.
- ★ When it not required to use this mechanism, set the pre-focusing dial ① to the uppermost position.

4-3 Stage

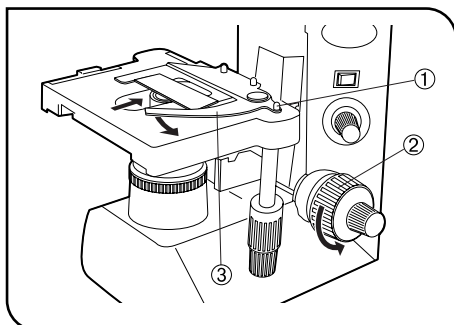

Fig. 13

1

Placing the Specimen

(Fig. 13)

★Releasing the curved finger with great force or suddenly releasing your grip on the curved finger knob ① while releasing the curved finger will crack or damage the slide glass. Always place the specimen with great care.

Observation with Specimen Holder for Single Specimen Slide

1. Turn the coarse adjustment knob ② counterclockwise (in the direction of the arrow) to lower the stage.
2. Open the spring-loaded curved finger ③ on the specimen holder and place the specimen slide into the specimen holder from the front.
3. After placing the slide as far as it will go, gently release the curved finger ③.

Observation with Specimen Holder for Two Specimen Slides

1. Place the first specimen slide as described in steps 1 and 2 above, then place the second specimen slide so that it contacts the first specimen slide.
2. Gently release the curved finger ③.

Observation by Placing the Specimen Slide with One Hand

Place the specimen slide at the front of the stage, then slide the specimen slide on the stage surface to slowly and gradually open the curved finger in the direction of the arrow. Insert the specimen slide into the specimen holder until it is fully and properly seated in the specimen holder.

• Cover Glass

Use cover glasses of 0.17 mm thickness in order to allow the objectives exhibit their full performances.

• Specimen Slide

Use specimen slides of 0.9 to 1.4 mm thickness. Using thicker specimen slides may result in inaccurate imaging of the field iris diaphragm image on the specimen.

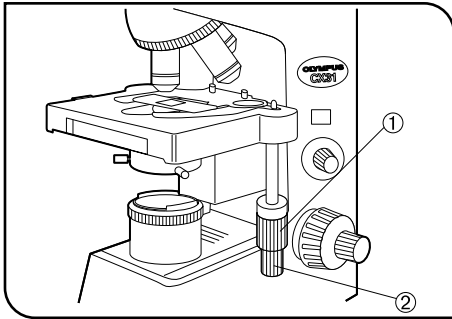

Fig. 14

2 Moving the Specimen (Fig. 14)

Turn the upper knob which is the Y-axis knob ① to move the specimen in the vertical direction, and turn the lower knob which is the X-axis knob ② to move it in the horizontal direction.

★Do not use the specimen holder or stage to move the specimen, for this will damage the rotating mechanisms of the knobs.

★When the stage and specimen holder are stopped by the pre-focusing dial, the tension of the X-axis/Y-axis knobs increases. In this case, do not attempt to turn the knobs to move the stage beyond the stopped position.

4-4 Observation Tube

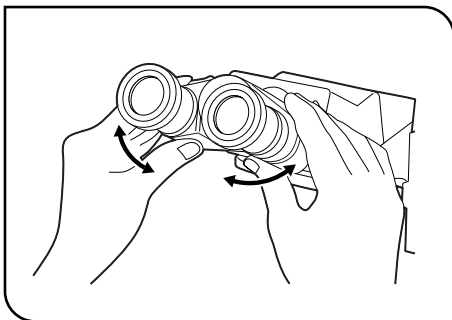

Fig. 15

1 Adjusting the Interpupillary Distance (Fig. 15)

▲Be careful not have your finger caught by the clearance below the binocular tube during interpupillary distance adjustment.

While looking through the eyepieces, adjust for binocular vision until the left and right fields of view coincide completely. The index dot • indicates the interpupillary distance.

◎Note your interpupillary distance so that it can be quickly duplicated.

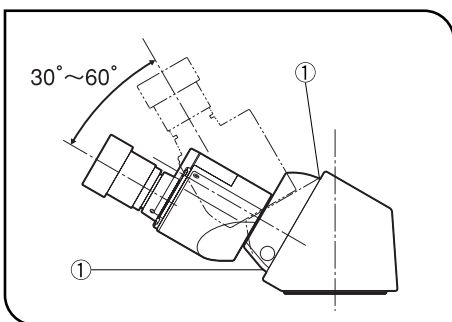

Fig. 16

2 Adjusting the Tilt (CX31RTBISF frame only) (Fig. 16)

◎The tilting observation tube can be adjusted to a height and angle suitable for ease of observation.

Hold the binocular section with both hands and move it up or down as desired.

★To prevent damage to the mechanism, do not apply an excessive force above or below the upper and lower stop positions.

▲Be careful not to have your finger by the clearance ① on the cover during tilt adjustment.

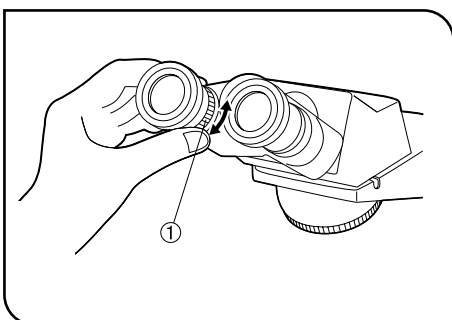

Fig. 17

3 Adjusting the Diopter (Fig. 17)

1. Looking through the right eyepiece with your right eye, rotate the coarse and fine adjustment knobs to bring the specimen into focus.

2. Looking through the left eyepiece with your left eye, turn the diopter adjustment ring ① to focus on the specimen.

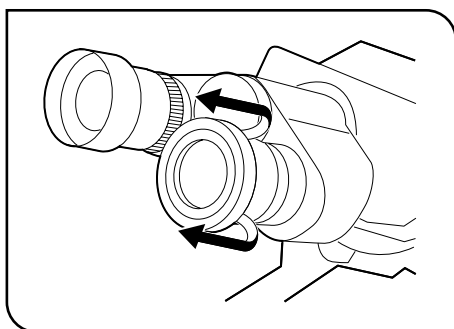

Fig. 18

4 Using the Eye Shades (Fig. 18)

When Wearing Eyeglasses

Use with the eye shades in the normal, folded-down position. This will prevent the eyeglasses from contacting and scratching the eyepieces.

When Not Wearing Eyeglasses

Extend the folded eye shades in the direction of the arrow for efficient use of the eyeshades by preventing extraneous light from entering between the eyepieces and eyes.

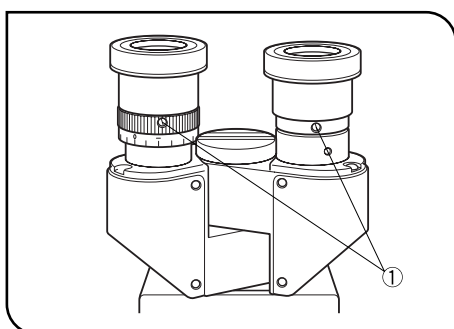

Fig. 19

5 Using the Eyepiece Micrometer Disk (Optional) (Figs. 19 & 20)

Ⓞ Prepare one eyepiece micrometer disk (diameter 20.4 mm, thickness 1 mm) and two 20.4-RH reticle holders (available as 2-piece set).

The field number becomes 19.6 when the reticle holders are used.

When the tilting observation tube is used, the field number is fixed at 18 and does not change.

Ⓞ If your eye is poor in eyesight and cannot focus the micrometer, use eyeglasses to correct your vision.

1. Loosen the eyepiece clamping screws ① using a small, flat-blade screwdriver and remove both eyepieces. When the tilting observation tube is used, remove only the right eyepiece.

2. Hold the micrometer disk ② with the side with indications facing down and place it into a reticle holder ③.

★ **Be careful not to leave dirt on the micrometer disk, as it will be noticeable during observation.**

3. Screw the reticle holder ③ containing the micrometer disk ② into the bottom of an eyepiece.

Be sure to screw in all the way by hooking your nail into the notch ④ on the holder at the end.

4. Screw the other reticle holder, alone, into the other eyepiece in order to align the field number.

5. Attach the eyepieces again and tighten the clamping screws ①.

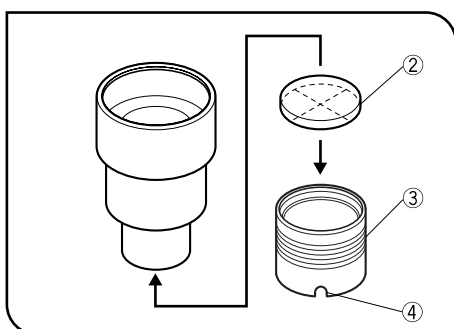

Fig. 20

4-5 Condenser

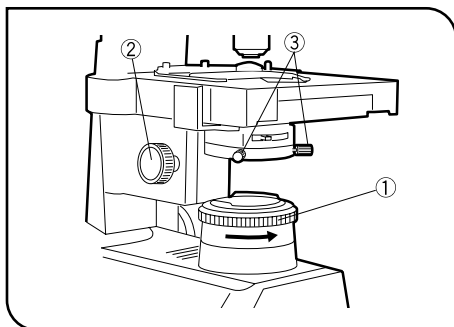

Fig. 21

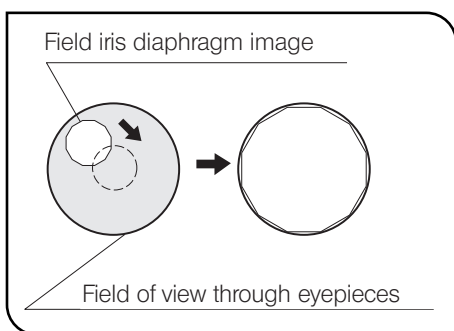

Fig. 22

1 Centering the Field Iris Diaphragm (Figs. 21 & 22)

1. With the 10X objective engaged and the specimen brought into focus, turn the field iris diaphragm ring ① counterclockwise to stop down the diaphragm to near its minimum size.
2. Turn the condenser height adjustment knob ② to bring the field iris diaphragm image into focus.
3. Rotate the two condenser centering knobs ③ to adjust so that the field iris diaphragm image is centered in the eyepiece field of view. (Figs. 21 & 22)
4. To check centration, open the field iris diaphragm until its image touches the perimeter of the field of view. If the image is not precisely inscribed in the field of view, center again. (Fig. 22)
5. When used for actual observation, open the field iris diaphragm until its image is slightly larger than the field of view.

2 Aperture Iris Diaphragm (Fig. 23)

- The aperture iris diaphragm determines the numerical aperture of the illumination system. Matching the numerical aperture ① of the illumination system with that of the objective provides better image resolution and contrast, and also increases the depth of focus.

Adjustment method

Align the aperture iris diaphragm knob ② with the NA value ① on the scale. The scale value should correspond to the NA number engraved on the objective.

Since the aperture iris diaphragm knob has a certain width, align the center line engraved on the knob with the scale indication.

When using a 100X objective, turn the aperture iris diaphragm knob ② all the way to 0.9 on the scale. (Fig. 23)

- Since the contrast of microscope specimens is ordinarily low, setting the condenser aperture iris diaphragm to **between 70% and 80%** of the NA of the objective in use is usually recommended.

★If the aperture iris diaphragm is set too small, image ghost may be observed.

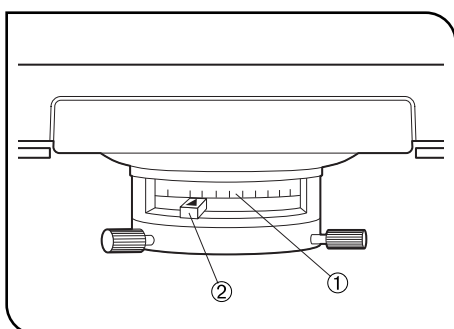

Fig. 23

4-6 Immersion Objectives

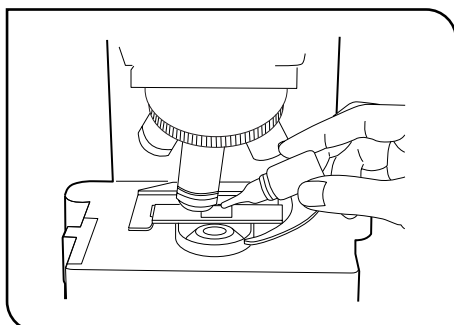

Fig. 24

1 Using the Immersion Objectives (Fig. 24)

◎The 100X objective is included only in the standard set of the CX31RBSFA combination.

★**Be sure to use the provided Olympus immersion oil.**

When the oil of other make is used the surface of the Top lens of Condenser may *be damaged*.

1. Focus on the specimen by switching the objectives from the lowest power to highest power.
2. Before engaging the immersion objective in the light path, place a drop of immersion oil provided with the 100X objective combination model onto the specimen at the area to be observed.
3. Turn the revolving nosepiece to engage the immersion objective, then focus using the fine adjustment knob.

★**Since air bubbles in the oil will affect the image quality, make sure that the oil is free of bubbles.**

To remove bubbles, turn the revolving nosepiece to move the oil immersion objective back and forth a few times.

◎If the condenser engraving shows a numerical aperture (NA) of 1.0 or higher, the number applies only when oil is applied between the slide glass and the top surface of the condenser. When oil is not present, the NA is about 0.9.

4. After use, remove oil from the objective front lens by wiping with gauze slightly moistened with an ether (70%)/alcohol (30%) mixture.

▲**Caution in use of the immersion oil**

If immersion oil penetrates in your eye or attaches to your skin, apply the following treatment immediately.

Eye: Rinse with fresh water (for more than 15 minutes)

Skin: Wash with water and soap.

When the appearance of your eye or skin is altered or pain continues, immediately consult the doctor.

5 TROUBLESHOOTING GUIDE

Under certain conditions, performance of the unit may be adversely affected by factors other than defects. If problems occur, please review the following list and take remedial action as needed. If you cannot solve the problem after checking the entire list, please contact your local Olympus representative for assistance.

Problem	Cause	Remedy	Page
1. Optical System			
a) Field of view is obscured or not evenly illuminated	Revolving nosepiece is not correctly engaged.	Make sure that revolving nosepiece clicks properly into place.	15
	Field iris diaphragm is not properly centered.	Center it.	13
	Field iris diaphragm is stopped down too far.	Open it to an optimum stop position.	8
	Dirt/dust on objective, eyepieces, condenser or light exit glass.	Clean them.	3
b) Dirt or dust is visible in the field of view.	Dirt/dust on light exist glass	Clean thoroughly.	3
	Dirt/dust on top lens of condenser		
	Dirt/dust on the specimen		
	Dirt/dust on eyepiece		
c) Image shows diffraction.	Condenser is lowered too far.	Adjust the condenser height position.	13
	Aperture iris diaphragm is stopped down too far.	Open it.	13
d) Visibility is poor. <ul style="list-style-type: none"> • Image is not sharp. • Contrast is poor. • Details are indistinct. 	Objective is not engaged correctly in light path.	Make sure that revolving nosepiece clicks into place correctly.	5
	Dirt/dust on front lens of objective.	Clean it thoroughly.	3
	Immersion oil is not being used with an oil immersion objective.	Use immersion oil.	14
	Immersion oil contains bubbles.	Remove bubbles.	14
	Recommended immersion oil is not used.	Use the specified immersion oil.	14
	Dirt/dust on specimen.	Clean it.	3
	Dirt/dust on condenser.		
e) One side of image is blurred. Image seems to waver.	Objective is not engaged correctly in light path.	Make sure that revolving nosepiece clicks into place correctly.	5
	Specimen is not correctly mounted on stage.	Place specimen correctly on top of stage and secure it with specimen holder.	10

Problem	Cause	Remedy	Page
2. Coarse/Fine Focus Adjustment			
a) Coarse adjustment knob is hard to turn.	Tension adjustment ring is overtightened.	Loosen it.	9
b) Stage drifts down by itself or focus is lost during observation.	Tension adjustment ring is too loose.	Tighten it.	9
c) Coarse adjustment will not go all the way up.	Simplified pre-focusing dial is keeping the stage down.	Set stopper mechanism to uppermost position.	9
d) Coarse adjustment will not go all the way down.	Condenser holder is too low.	Raise condenser holder.	13
e) Objective makes contact with specimen before focus is obtained.	Specimen is mounted upside down.	Mount specimen correctly.	-
3. Observation Tube			
Field of view of one eye does not match that of the other.	Interpupillar distance is incorrect.	Adjust interpupillary distance.	11
	Incorrect diopter adjustment.	Adjust diopter.	11
	Your view is not accustomed to microscope observation.	Upon looking into eyepieces, try looking at overall field before concentrating on specimen range. You may also find it helpful to look up and into distance for a moment before looking back into microscope.	-
4. Stage			
Image blurs as you move specimen.	Specimen is not correctly positioned on the stage.	Mount specimen correctly by applying it on stage surface and inserting below specimen holder.	10
5. Objective Change			
Front lens of a high power objective comes into contact with specimen when it is engaged after a low-power objective.	Specimen is mounted upside down.	Mount specimen correctly.	-
	Cover glass is too thick.	Use 0.17 mm thick cover glass.	10
6. Electrical System			
a) Bulb does not light.	Bulb is not mounted.	Mount designated bulb.	6
	Bulb is burnt out.	Replace bulb.	6
	Power cord plug is not connected.	Connect power cord.	6
b) Bulb burns out almost immediately.	Wrong type of bulb is used.	Use correct bulb type.	6

6 SPECIFICATIONS

Item	Specification		
1. Optical system	UIS (Universal Infinity System) optical system		
2. Illumination	Illuminator built in. 6V 30W halogen bulb (PHILIPS 5761) (Average service time: Approximately 100 hr. when used as directed) 100-120 V/220-240 V $\sqrt{}$, 0.85/0.45 A, 50/60 Hz		
3. Focusing	Stage height movement by roller guide (rack & pinion) Stroke per rotation: 36.8 mm Full stroke range: 25 mm Upper limit stopped by simplified pre-focusing dial Tension adjustment on coarse focus adjustment knob.		
4. Revolving nosepiece	4-position revolving nosepiece, fixed with inward tilt.		
5. Observation tube	Type	Binocular tube	Tilting binocular tube
	Field number	20	18
	Tube tilting angle	30°	30° to 60°
	Interpupillary distance adjustment	48 to 75 mm	48 to 75 mm
6. Stage	Size	188 mm x 134 mm	
	Movement range	76 mm (H) x 50 mm (V)	
	Specimen holder	2-slide holder	
7. Condenser	Type	Abbe condenser (with built-in daylight filter)	
	NA.	1.25 (with oil immersion)	
	Aperture iris diaphragm	Built in	
8. Dimensions & weight	233(W) x 411(H) x 367.5(D) mm, approx.77kg(16.9 lb.)		
9. Operating environment	<ul style="list-style-type: none"> • Indoor use. • Altitude: Max. 2000 meters • Ambient temperature: 5° to 40°C (41° to 104°F) • Maximum relative humidity: 80% for temperatures up to 31°C (88°F), decreasing linearly through 70% at 34°C (93°F), 60% at 37°C (99°F), to 50% relative humidity at 40°C (104°F) • Supply voltage fluctuations; Not to exceed $\pm 10\%$ of the normal voltage. • Pollution degree: 2 (in accordance with IEC60664) • Installation/Overvoltage category: II (in accordance with IEC60664) 		

7 OPTICAL CHARACTERISTICS

The following table shows the optical characteristics of combinations of eyepieces and objectives. The figure on the right shows the performance data engraved on the objectives.

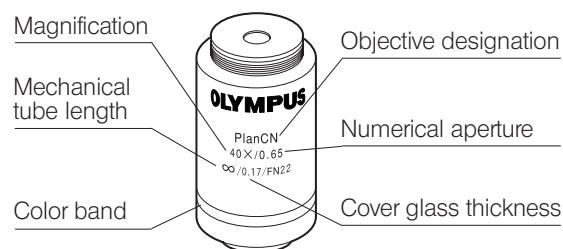

Characteristics Objective	Magnification	NA	W.D. (mm)	Cover Glass Thickness	Resolution (μm)	10X eyepieces (See Note)			Remark
						Total Mag.	Depth of Focus (μm)	Field of View	
Plan CN	4X	0.10	18.5	–	3.36	40X	175.0	5.0(4.5)	
Plan Achromat (FN 22)	10X	0.25	10.6	–	1.34	100X	28.0	2.0(1.8)	
	40X	0.65	0.6	0.17	0.52	400X	3.04	0.5(0.45)	
	*100XO	1.25	0.13	–	0.27	1000X	0.69	0.2(0.18)	(Oil immersion)

*Included only in the standard set of the CX31RBSFA combination.

(Note) Field number of 10X eyepieces

- With the binocular tube, the FN is 20 and the actual field of view is the figure before ().
- With the tilting binocular tube, the FN is 18 and the actual field of view is the figure inside ().

Glossary

Working distance (W.D.): The distance from the cover glass surface to the nearest point of the objective.

Numerical aperture (NA): The N.A. value represents a performance number which can be compared to the relative aperture (f-number) of a camera lens. The higher NA, the higher the resolving power.

Resolving power: The ability to differentiate two points, i.e., the minimum distance by which the objects must be separated in order to be revealed as two separate objects.

Focal depth: The depth in the image through which the focused image will appear uniformly sharp. As the aperture iris diaphragm is stopped down, the focal depth becomes greater. The greater the NA of an objective, the shorter the focal depth.

Field number: A number that represents the diameter in mm of the image of the field diaphragm that is formed by the lens in front of it.

Field of view diameter: The actual size of the field of view in millimeters.

Total magnification: Equals the objective magnification multiplied by the eyepiece magnification.

■ PROPER SELECTION OF THE POWER SUPPLY CORD

If no power supply cord is provided, please select the proper power supply cord for the equipment by referring to "Specifications" and "Certified Cord" below.

CAUTION : In case you use a non-approved power supply cord for Olympus products, Olympus can no longer warrant the electrical safety of the equipment.

Specifications

Voltage Rating	125V AC (for 100-120V AC area) or, 250V AC (for 220-240V AC area)
Current Rating	6A minimum
Temperature Rating	60 minimum
Length	3.05 m maximum
Fittings Configuration	Grounding type attachment pulg cap Opposite teminates in molded-on IEC configuration appliance coupling.

Table 1 Certified Cord

A power supply cord should be certified by one of the agencies listed in Table 1, or comprised of cordage marked with an agency marking per Table 1 or marked per Table 2. The fittings are to be marked with at least one of agencies listed in Table 1. In case you are unable to buy locally in your country the power supply cord which is approved by one of the agencies mentioned in Table 1, please use replacements approved by any other equivalent and authorized agencies in your country.



















Country	Agency	Certification Mark	Country	Agency	Certification Mark
Argentina	IRAM		Italy	IMQ	
Australia	SAA		Japan	JET, JQA, TÜV, UL-APEX / MITI	
Austria	ÖVE		Netherlands	KEMA	
Belgium	CEBEC		Norway	NEMKO	
Canada	CSA		Spain	AEE	
Denmark	DEMKO		Sweden	SEMKO	
Finland	FEI		Switzerland	SEV	
France	UTE		United Kingdom	ASTA, BSI	
Germany	VDE		U.S.A.	UL	
Ireland	NSAI				

Table 2 HAR Flexible Cord

APPROVAL ORGANIZATIONS AND CORDAGE HARMONIZATION MARKING METHODS

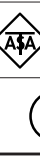
Approval Organization	Printed or Embossed Harmonization Marking (May be located on jacket or insulation of internal wiring)		Alternative Marking Utilizing Black-Red-Yellow Thred (Length of color section in mm)		
			Black	Red	Yellow
Comite Electrotechnique Belge (CEBEC)	CEBEC	<HAR>	10	30	10
Verband Deutscher Elektrotechniker (VDE) e.V. Prüstelle	<VDE>	<HAR>	30	10	10
Union Technique de l'Electricité (UTE)	USE	<HAR>	30	10	30
Instituto Itaaliano del Marchio di Qualita' (IMQ)	IEMMEQU	<HAR>	10	30	50
British Approvals Service for Electric Cables (BASEC)	BASEC	<HAR>	10	10	30
N.V. KEMA	KEMA-KEUR	<HAR>	10	30	30
SEMKO AB Svenska Elektriska Matenelkontrollanstalter	SEMKO	<HAR>	10	10	50
Österreichisher Verband für Elektrotechnik (ÖVE)	<ÖVE>	<HAR>	30	10	50
Danmarks Elektriske Materialkontroll (DEMKO)	<DEMKO>	<HAR>	30	10	30
National Standards Authority of Ireland (NSAI)	<NSAI>	<HAR>	30	30	50
Norges Elektriske Materiellkontroll (NEMKO)	NEMKO	<HAR>	10	10	70
Asociacion Electrotecnica Y Electronica Espanola (AEE)	<UNED>	<HAR>	30	10	70
Hellenic Organization for Standardization (ELOT)	ELOT	<HAR>	30	30	70
Instituto Portages da Qualidade (IPQ)	np	<HAR>	10	10	90
Schweizerischer Elektro Technischer Verein (SEV)	SEV	<HAR>	10	30	90
Elektriska Inspektoratet	SETI	<HAR>	10	30	90

Underwriters Laboratories Inc. (UL)
Canadian Standards Association (CSA)

SV, SVT, SJ or SJT, 3 X 18AWG
SV, SVT, SJ or SJT, 3 X 18AWG

OLYMPUS®



OLYMPUS CORPORATION

Shinjuku Monolith, 3-1, Nishi Shinjuku 2-chome, Shinjuku-ku, Tokyo, Japan



OLYMPUS EUROPA HOLDING GMBH

Wendenstraße 14-18, 20097 Hamburg, Germany

OLYMPUS AMERICA INC.

3500 Corporate Parkway, P.O. Box 610, Center Valley, PA 18034-0610, U.S.A.

OLYMPUS SURGICAL & INDUSTRIAL AMERICA INC.

One Corporate Drive, Orangeburg, NY 10962, U.S.A.

OLYMPUS SINGAPORE PTE LTD.

491B River Valley Road, #12-01/04 Valley Point Office Tower, Singapore 248373

OLYMPUS AUSTRALIA PTY. LTD.

31 Gilby Road, Mount Waverley, VIC., 3149, Australia

OLYMPUS LATIN AMERICA, INC.

5301 Blue Lagoon Drive, Suite 290 Miami, FL 33126, U.S.A.

